

Please write clearly in block capitals.

Centre number

--	--	--	--	--

Candidate number

--	--	--	--

Surname

---

Forename(s)

---

Candidate signature

---

I declare this is my own work.

# GCSE PHYSICS

# H

Higher Tier Paper 1

Time allowed: 1 hour 45 minutes

## Materials

For this paper you must have:

- a ruler
- a scientific calculator
- the Physics Equations Sheet (enclosed).

## Instructions

- Use black ink or black ball-point pen. Pencil should only be used for drawing.
- Fill in the boxes at the top of this page.
- Answer **all** questions in the spaces provided.
- Do not write outside the box around each page or on blank pages.
- Do all rough work in this book. Cross through any work you do not want to be marked.
- If you need extra space for your answer(s), use the lined pages at the end of this book. Write the question number against your answer(s).
- In all calculations, show clearly how you work out your answer.

## Information

- The maximum mark for this paper is 100.
- The marks for questions are shown in brackets.
- You are expected to use a calculator where appropriate.
- You are reminded of the need for good English and clear presentation in your answers.

For Examiner's Use	
Question	Mark
1	
2	
3	
4	
5	
6	
7	
8	
9	
10	
11	
<b>TOTAL</b>	



Answer **all** questions in the spaces provided.

0 1

**Figure 1** shows a large wind farm off the coast of the UK.

**Figure 1**



The mean power output of the wind farm is 696 MW, which is enough power for 580 000 homes.

0 1 . 1

Calculate the mean power needed for 1 home.

Give your answer in watts.

**[2 marks]**

---

---

---

---

---

Mean power needed for 1 home = \_\_\_\_\_ W



**0 1 . 2** On one day the demand for electricity in the UK was 34 000 MW.

Suggest **two** reasons why wind power was not able to meet this demand.

**[2 marks]**

1 \_\_\_\_\_  
\_\_\_\_\_  
\_\_\_\_\_

2 \_\_\_\_\_  
\_\_\_\_\_  
\_\_\_\_\_

**0 1 . 3** Some of the energy from the wind used to rotate a wind turbine is wasted.

An engineer oils the mechanical parts of a wind turbine.

Explain how oiling would affect the efficiency of the wind turbine.

**[3 marks]**

\_\_\_\_\_  
\_\_\_\_\_  
\_\_\_\_\_  
\_\_\_\_\_  
\_\_\_\_\_

**0 1 . 4** In most homes in the UK there are many different electrical devices.

Explain why people should be encouraged to use energy efficient electrical devices.

**[2 marks]**

\_\_\_\_\_  
\_\_\_\_\_  
\_\_\_\_\_  
\_\_\_\_\_  
\_\_\_\_\_



**0 2**

**Figure 2** shows a rock found by a student on a beach.

To help identify the type of rock, the student took measurements to determine its density.

**Figure 2**

**0 2****. 1**

Describe a method the student could use to determine the density of the rock.

**[6 marks]**

---

---

---

---

---

---

---

---

---

---

---

---

---

---

---



The student determined the density of the rock to be  $2.55 \pm 0.10 \text{ g/cm}^3$ .

**0 2 . 2** What are the maximum and minimum values for the density of the rock?

**[1 mark]**

Maximum density = \_\_\_\_\_  $\text{g/cm}^3$

Minimum density = \_\_\_\_\_  $\text{g/cm}^3$

**0 2 . 3** **Table 1** gives the density of five different types of rock.

**Table 1**

Type of rock	Density in $\text{g/cm}^3$
Basalt	$2.90 \pm 0.10$
Chalk	$2.35 \pm 0.15$
Flint	$2.60 \pm 0.10$
Sandstone	$2.20 \pm 0.20$
Slate	$2.90 \pm 0.20$

Which two types of rock in **Table 1** could be the type of rock the student had?

**[1 mark]**

Tick (✓) **one** box.

Basalt or chalk

Chalk or flint

Flint or sandstone

Sandstone or slate

**Question 2 continues on the next page**

**Turn over ►**



0	2	.	4
---	---	---	---

The student only took one set of measurements to determine the density of the rock.

Explain why taking the measurements more than once may improve the accuracy of the density value.

**[2 marks]**

---

---

---

---

10
----



**Turn over for the next question**

*Do not write  
outside the  
box*

**DO NOT WRITE ON THIS PAGE  
ANSWER IN THE SPACES PROVIDED**

**Turn over ►**



0 3

An engineering company has invented pavement tiles that generate electricity as people walk on them.

**Figure 3** shows someone walking on the pavement tiles.

**Figure 3**



Use the Physics Equations Sheet to answer questions **03.1** and **03.2**.

0 3 . 1

What equation links current ( $I$ ), potential difference ( $V$ ) and power ( $P$ )?

**[1 mark]**

Tick (✓) **one** box.

$$P = \frac{V}{I} \quad \square$$

$$P = V \times I \quad \square$$

$$I = P \times V \quad \square$$

$$V = I^2 \times P \quad \square$$





0 3 . 2

When a person walks on a tile, a potential difference of 40 V is induced across the tile.

The power output of the tile is 4.4 W.

Calculate the current in the tile.

**[3 marks]**

---

---

---

---

---

Current = \_\_\_\_\_ A

**Question 3 continues on the next page**



Use the Physics Equations Sheet to answer questions **03.3** and **03.4**.

**03.3** What equation links efficiency, total power input and useful power output?

**[1 mark]**

Tick (✓) **one** box.

Efficiency =  $\frac{\text{useful power output}}{\text{total power input}}$

Efficiency =  $\frac{\text{total power input}}{\text{useful power output}}$

Efficiency = useful power output  $\times$  total power input

**03.4** The tiles are used to power LED lights in the pavement.

An LED light has a total power input of 4.0 W.

The efficiency of the LED light is 0.85

Calculate the useful power output of the LED light.

**[3 marks]**

---



---



---



---



---

Useful power output = \_\_\_\_\_ W

**8**



**Turn over for the next question**

*Do not write  
outside the  
box*

**DO NOT WRITE ON THIS PAGE  
ANSWER IN THE SPACES PROVIDED**

**Turn over ►**



0 4

A student investigated the insulating properties of different materials.

**Figure 4** shows some of the equipment used by the student.

**Figure 4**

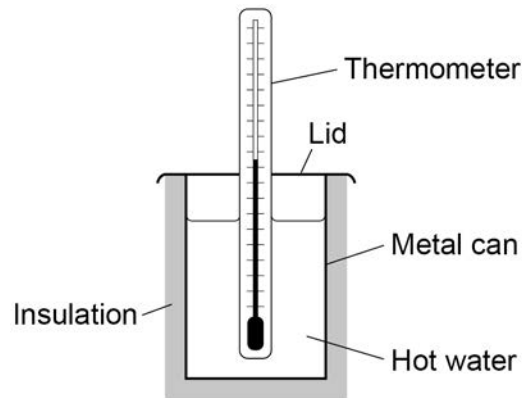

This is the method used:

1. Wrap insulating material around the can.
2. Put a fixed volume of boiling water in the can.
3. Place the lid on the top of the can.
4. Measure the time taken for the temperature of the water to decrease by a fixed amount.
5. Repeat steps 1–4 using the same thickness of different insulating materials.

0 4 . 1

Identify the independent variable and the dependent variable in this investigation.

**[2 marks]**

Independent variable \_\_\_\_\_

Dependent variable \_\_\_\_\_



The student used two different types of thermometer to measure the temperature changes.

**Figure 5** shows a reading on each thermometer.

**Figure 5**

Thermometer A

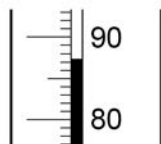

Thermometer B

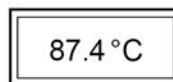

**0 4 . 2** What is the resolution of thermometer B?

[1 mark]

Resolution = \_\_\_\_\_ °C

**0 4 . 3** Thermometer A is more likely to be misread.

Give **one** reason why.

[1 mark]

---



---



---

**Question 4 continues on the next page**

**Turn over ►**



0 4 . 4

For one type of insulating material, the temperature of the water decreased from  $85.0\text{ }^{\circ}\text{C}$  to  $65.0\text{ }^{\circ}\text{C}$ .

The energy transferred from the water was  $10.5\text{ kJ}$ .

specific heat capacity of water =  $4200\text{ J/kg }^{\circ}\text{C}$

Calculate the mass of water in the can.

Use the Physics Equations Sheet.

[3 marks]

---

---

---

---

---

Mass = \_\_\_\_\_ kg



**0 4 . 5** **Table 2** shows the results for two insulating materials.

**Table 2**

<b>Material</b>	<b>Time for temperature to decrease by 20 °C in seconds</b>
X	450
Y	745

Explain how the results in **Table 2** can be used to compare the thermal conductivity of the two materials.

**[2 marks]**

---

---

---

---

---

---

---

---

**9**

**Turn over for the next question**

**Turn over ►**



0 5

A student rubbed a plastic rod with a cloth.

The rod became negatively charged and the cloth became positively charged.

0 5 . 1

Explain why the cloth became positively charged.

[3 marks]

---



---



---



---



---



---

**Figure 6** shows the negatively charged rod on a balance.

**Figure 6**

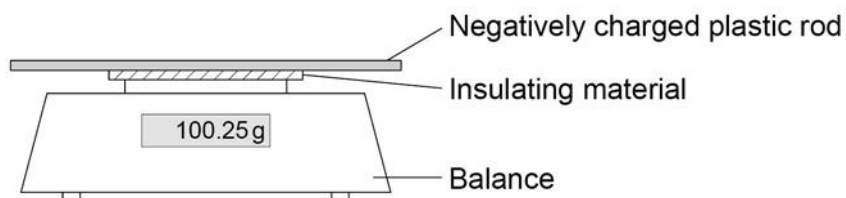

**Figure 7** shows another charged rod being held stationary above the rod on the balance.

The rods do not touch each other.

**Figure 7**

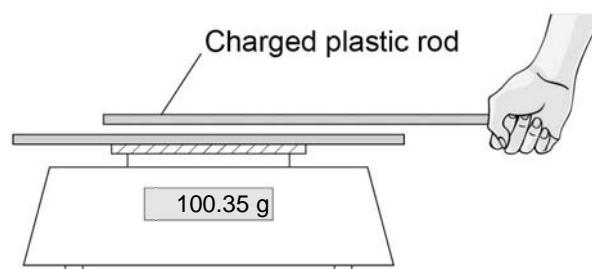



**0 5 . 2** Explain why the reading on the balance increases.

**[3 marks]**

---

---

---

---

---

---

---

**0 5 . 3** The balance had a zero error.

The zero error is not important in this experiment.

Give the reason why.

**[1 mark]**

---

---

**0 5 . 4** A negatively charged rod is held near an earthed conductor.

Explain why a spark jumps between the negatively charged rod and the earthed conductor.

**[3 marks]**

---

---

---

---

---

---

---

**10**

Turn over ►



0 6

Figure 8 shows how electricity is supplied to consumers by the National Grid.

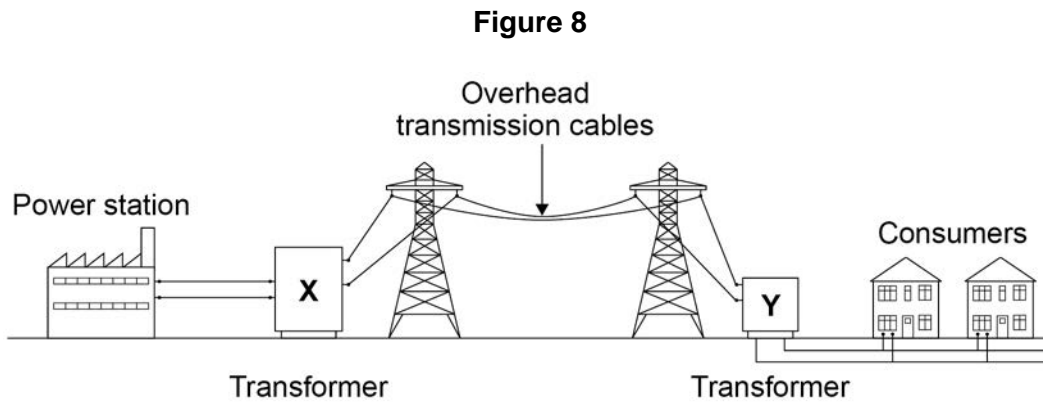

0 6 . 1

Explain why transformer X is used in the National Grid.

[4 marks]

---



---



---



---



---



---



---



---



---



---

0 6 . 2

Explain why transformer Y is used in the National Grid.

[2 marks]

---



---



---



---



**0 6 . 3** The town of Hornsdale in Australia has electricity supplied by a huge battery.

On one day the battery transferred  $3.24 \times 10^{11}$  J of energy to the town.

The potential difference of the town's electricity supply is 230 V.

Calculate the charge flow to the town on this day.

Use the Physics Equations Sheet.

Give your answer to **3** significant figures.

**[4 marks]**

---

---

---

---

---

Charge flow (3 significant figures) = \_\_\_\_\_ C

**10**

**Turn over for the next question**

**Turn over ►**



0 7

Alpha particles, beta particles and gamma rays are types of nuclear radiation.

0 7 . 1

What does an alpha particle consist of?

[1 mark]

---



---

0 7 . 2

A krypton (Kr) nucleus decays into a rubidium (Rb) nucleus by emitting a beta particle.

Complete the nuclear equation for this decay by writing the missing number in each box.

[2 marks]

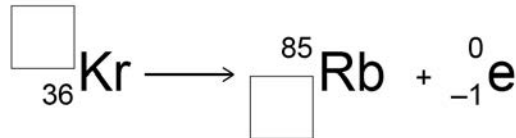

0 7 . 3

Internal contamination of the human body means radioactive material is inside the human body.

Explain how the risk from internal contamination is different to the risk from external irradiation by a source of alpha radiation.

[5 marks]

---



---



---



---



---



---



---



---



---



---



---



---



---



---



---



---



**Turn over for the next question**

*Do not write  
outside the  
box*

**DO NOT WRITE ON THIS PAGE  
ANSWER IN THE SPACES PROVIDED**

**Turn over ►**



0 8

A student determined the specific latent heat of vaporisation of water.

**Figure 9** shows some of the equipment used.

**Figure 9**

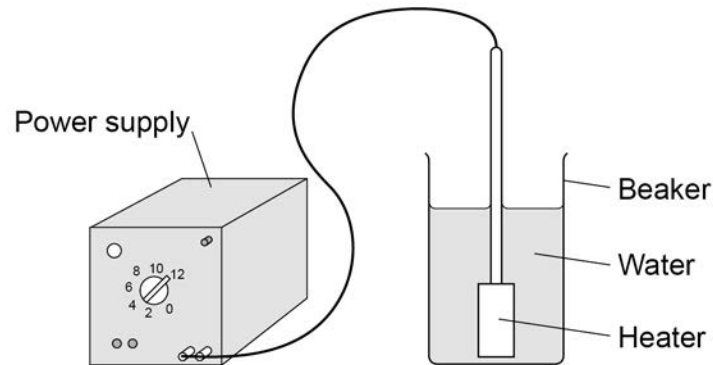

This is the method used:

1. Put 50 cm<sup>3</sup> of water in a beaker.
2. Measure the mass of the beaker and water.
3. Use a heater to boil the water and keep it boiling for 600 seconds.
4. Measure the mass of the beaker and water after 600 seconds.

0 8 . 1

What measuring instrument should be used to measure the volume of water?

[1 mark]

---

0 8 . 2

What is a hazard in the student's investigation?

[1 mark]

Tick (✓) **one** box.

burns

boiling water

heatproof gloves

safety goggles



0 8 . 3

The initial mass of the beaker and water was 0.080 kg.

The final mass of the beaker and water was 0.071 kg.

The energy transferred by the immersion heater as the water boiled was 25 200 J.

Calculate the specific latent heat of vaporisation of water given by the student's data.

Give the unit.

Use the Physics Equations Sheet.

**[5 marks]**

---

---

---

---

---

---

---

---

---

---

---

---

---

---

---

---

---

---

---

---

---

---

---

---

Specific latent heat of vaporisation = \_\_\_\_\_ Unit \_\_\_\_\_

**Question 8 continues on the next page**



**Turn over ►**

**0 8 . 4**

Some thermal energy was transferred to the surroundings while the water was being heated.

Explain how this affected the student's value for the specific latent heat of vaporisation of water.

**[2 marks]**

---

---

---

---

**0 8 . 5**

Some of the water evaporated before its temperature reached 100 °C.

Explain how this affected the student's value for the specific latent heat of vaporisation of water.

**[2 marks]**

---

---

---

---

**11**



**Turn over for the next question**

*Do not write  
outside the  
box*

**DO NOT WRITE ON THIS PAGE  
ANSWER IN THE SPACES PROVIDED**

**Turn over ►**



0 9

**Figure 10** shows a girl doing an experiment to determine her power output by running to the top of some stairs.

**Figure 10**

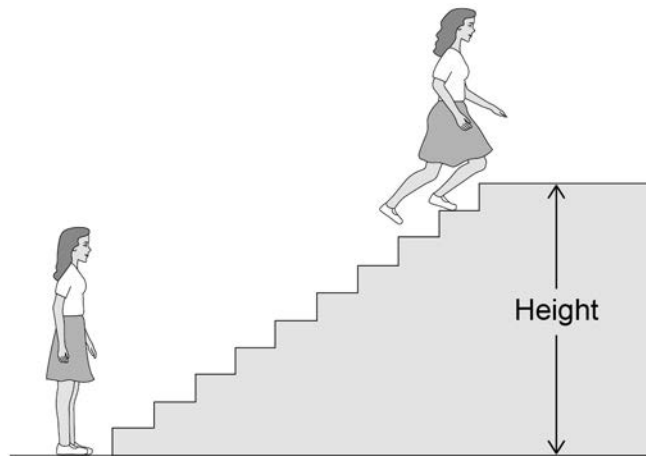

0 9 . 1

The mass of the girl was 60.0 kg.

The height of the stairs was 175 cm.

The girl ran to the top of the stairs in 1.40 s.

gravitational field strength = 9.8 N/kg

Calculate the power output of the girl.

Use the Physics Equations Sheet.

**[5 marks]**

---



---



---



---



---



---



---



---

Power = \_\_\_\_\_ W



**0 9 . 2** The **total** power output of the girl was greater than the answer to question **09.1**.

Suggest **two** reasons why.

**[2 marks]**

1 \_\_\_\_\_

2 \_\_\_\_\_

**0 9 . 3** A boy took more than 1.40 s to run up the same stairs.

The power output of the boy was the same as the power output of the girl.

What conclusion can be made about the boy's mass?

**[1 mark]**

Tick (✓) **one** box.

The boy's mass was greater than the girl's mass.

The boy's mass was lower than the girl's mass.

The boy's mass was the same as the girl's mass.

8

**Turn over for the next question**

**Turn over ►**



**1 0**

**Figure 11** shows a student launching a toy aeroplane.

To launch the aeroplane, the student pulls on it to stretch the spring and then releases it.

**Figure 11**

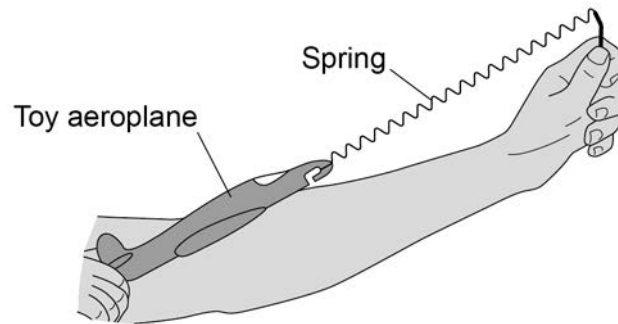
**1 0****. 1**

Just before the toy aeroplane is released, the spring has an extension of 0.12 m.

mass of aeroplane = 0.020 kg

spring constant of the spring = 50 N/m

Calculate the maximum speed of the toy aeroplane just after it is launched.

Use the Physics Equations Sheet.

Give the unit.

**[6 marks]**

---

---

---

---

---

---

---

---

---

---

---

---

---

---

---

---

---

---

---

---

---

---

---

---

Speed = \_\_\_\_\_ Unit \_\_\_\_\_



1 0 . 2 Complete the sentence.

[1 mark]

As the aeroplane moves upwards through the air there is a decrease  
in the \_\_\_\_\_ energy of the aeroplane.

1 0 . 3 Give **one** factor which would increase the distance the toy aeroplane travels  
horizontally before hitting the ground.

[1 mark]

---

---

8

**Turn over for the next question**

**Turn over ►**



1	1
---	---

**Figure 12** shows some hair straighteners.

Hair straighteners contain heating elements.

**Figure 12**



1	1	.	1
---	---	---	---

When the hair straighteners reach normal operating temperature, an LED turns on.

Draw the circuit symbol for an LED in the box.

**[1 mark]**

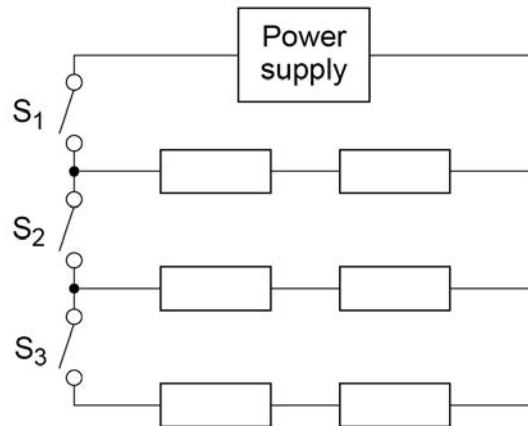

**Figure 13** shows the circuit diagram for the hair straighteners.

Each resistor represents a heating element.

The power output of the hair straighteners can be changed by closing different switches.

**Figure 13**



1 1 . 2

Why do the hair straighteners **not** turn on when only switch  $S_2$  is closed?

[1 mark]

---



---

**Question 11 continues on the next page**

**Turn over ►**



1 1 . 3 The hair straighteners have a maximum power output of 120 W.

The energy transferred to the hair straighteners to reach normal operating temperature is 3.6 kJ.

Calculate the time taken for the hair straighteners to reach normal operating temperature when operating at maximum power.

Use the Physics Equations Sheet.

**[4 marks]**

---

---

---

---

---

---

---

Time = \_\_\_\_\_ seconds





1 1 . 4 Figure 14 shows the hair straighteners circuit with switch  $S_1$  closed.

Figure 14

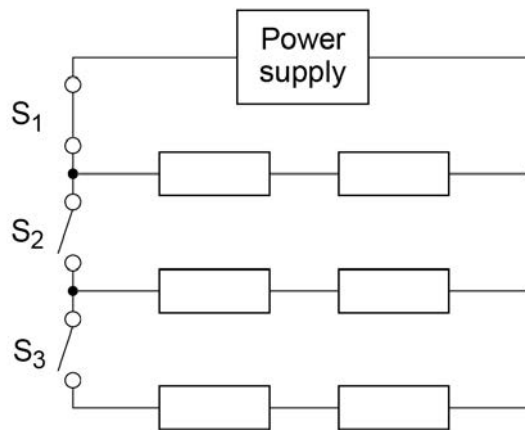

Switch  $S_2$  and switch  $S_3$  are then closed at the same time.

Explain what happens to the power output of the power supply.

[3 marks]

---



---



---



---



---



---



---



---



---



---

9

END OF QUESTIONS



**There are no questions printed on this page**

*Do not write  
outside the  
box*

**DO NOT WRITE ON THIS PAGE  
ANSWER IN THE SPACES PROVIDED**





